

IoT based Smart Agriculture using Machine Learning

Kasara Sai Pratyush Reddy
Computer Science and Engineering
Institute of Aeronautical Engineering
Hyderabad, India

Y Mohana Roopa
Computer Science and Engineering
Institute of Aeronautical Engineering
Hyderabad, India
ymohanaroopa@gmail.com

Kovvada Rajeev L N
Computer Science and Engineering
Computer Science and Engineering
Institute of Aeronautical Engineering
Hyderabad, India

Narra Sai Nandan
Computer Science and Engineering
Institute of Aeronautical Engineering
Hyderabad, India

Abstract—Agriculture balances both food requirement for mankind and supplies indispensable raw materials for many industries, and it is the most significant and fundamental occupation in India. The advancement in inventive farming techniques is gradually enhancing the crop yield making it more profitable and reduce irrigation wastages. The proposed model is a smart irrigation system which predicts the water requirement for a crop, using machine learning algorithm. Moisture, temperature and humidity are the three most essential parameters to determine the quantity of water required in any agriculture field. This system comprises of temperature, humidity and moisture sensor, deployed in an agricultural field, sends data through a microprocessor, developing an IoT device with cloud. Decision tree algorithm, an efficient machine learning algorithm is applied on the data sensed from the field in to predict results efficiently. The results obtained through decision tree algorithm is sent through a mail alert to the farmers, which helps in decision making regarding water supply in advance.

Keywords—*Irrigation System, IoT, Soil Moisture, Temperature, Humidity, Decision Tree Algorithm, Mail alert.*

I. INTRODUCTION

Internet of Things (IoT) is an advanced technology for monitoring and controlling device anywhere in the world. It can connect devices with living things. Internet of Things is making a significant mark in many fields. Nowadays, the adaptive nature of IoT has transformed, can be utilized by an ordinary user. Several methodologies that IoT has developed made man's life easier and comfortable like smart education, cities, e-health sector and automation [13]. Apart from man's comforts, these methodologies should be implemented on basic needs like food, which can be achieved from the

agricultural fields. World Bank has estimated that more than 50% food need to be produced before 2050 if the population trend is at current rate. But the present climate changes wouldn't support such huge crop production. So field based sensors, drones, advanced tractors and hydroponic farming may help future farmers to yield more crop, at very low prices. Therefore, the necessity for elegant farming is growing exponentially. An enormous amount of the water withdrawals is occurring for farming. So, more precautions and discussions should be made in the farming area. Indeed, agriculture profitability is a major part of the arrangement.

India is a nation which is well known for its agriculture. In corresponding to growing yields, its water system needs should be taken into notice. Harvests require legitimate irrigation system at proper time interims for them to grow well [11]. Agriculture is the field where there is a high demand for the labour. The reason for the decrease in work power was very low because that adolescents were not enthusiastic about farming part and they didn't discover a lot of opportunities. Subsequently, farmers who devote their times to develop crops in enormous regions needed to spend their entire day outside to guarantee that the harvests are being developed appropriately. Farmers once in a while had great controls on crops and furthermore experienced incredible misfortunes because of unexpected and difficult climate conditions.

The work presented in this report was highly motivated by the realization of future water scarcity that is going to create a great havoc. Agriculture is the significant occupation in India and these fields consumes large amount of water. Greater than 80% of water resources are

only used for the agriculture [7]. This continuous trend may affect the water resources to be completely diminished. Taking this into the consideration, a model was proposed to limit the water usage. For better land productivity, implementing smart technology in agricultural practices are need to be focused.

II. RELATED WORK

In [1], the authors have proposed an irrigation system which assists to diminish water wastage and to mechanize the water system structure for huge regions of cropland. The system evaluates the necessities of water in the crop based on the behavior of atmospheric temperature, humidity and soil moisture. The framework utilizes a machine learning technique and contrasts sensed values acquired from sensors and a limit values that has been given to the machine learning for further analysis. After this procedure, the ML algorithm cross checks the outcome acquired with whether forecast and afterward provides a decision whether water supply should be done or not [11]. The user gets an immediate notification on his mobile phone and he can decide to turn on the water supply with a simple click. Also, the framework has a web application and is useful if at any point the user needs to see the analytical sensor information and evaluate the changes in sensor readings all through a timeframe. Moreover, the framework can be aligned for various sort of plants, that is, the client is given a list of plant's decisions in his web application and mobile application [12].

. With this the farmer can pick the particular sort of plant that is being cultivated and get an increasingly exact threshold limit and in this manner a progressively precise irrigation prediction. In addition, an SMS alert can be coordinated by chance there is no web access. With this, the client would be informing about the predictions by means of a SMS and he can decide to turn on or off the water supply to the crop by answering to the SMS that the user received.

In [2], the authors have expressed IoT as the gateway between the things. They discussed the importance of watering and development of roofing system for the outdoor crop fields, highlighting the significant contribution of agriculture towards Thai economy. For more precise values, Kalman filtering techniques is used to remove noisy data in sensed information. Mainly the system comprises of soil moisture data and other physical factors retrieved from the sensors [10]. A decision tree model is utilized to calculate the accurate timing to start watering at particular standards. Besides, a mobile application is developed so that farmer can know the field status time to time.

In [3] the authors have elaborated and proposed an irrigation system using internet of things, mainly considering the wastage of water in the regions of South Algeria. Using Wireless Sensor Network (WSN), IoT along with Constrained Application Protocol (CoAP) a smart irrigation system was developed which can be easily managed and tracked to make sure the water usage more effectively. This system is corroborated to be low

cost and detailed and was importantly designed to manage the water supplying through internet.

In [4], the authors have discussed an automated irrigation system using an Android Operating System smartphone as a remote control. A soil moisture sensor sends a voltage signal proportional and analyzed with a constant threshold number taken from different soil compositions. This data is sent to raspberry pi through HC05 module to a mobile phone. The results are shown on a user interface which is developed to use smartphone as a remote control and to manage the irrigation system switching off or on. This system is considered as a feasible one, therefore can be utilized as a real-time application.

In [5], the authors have introduced IoT in order to detect the physical data and send it to the user. They also highlighted methodologies which can be utilized to provide solution to different problems like recognizing rodents, several risks to crops. IoT device is developed using python scripts, which can send a notification with no human interference.

In [6], the authors have discussed the concepts of web services and IoT which has a great capacity in handling the huge data regarding the cultivation field by using the concept of internet of things and other web services. This combination of cloud services and IoT has advanced quickly and also contributed a lot to develop numerous smart solutions for the problems in agricultural fields as well as problems faced by the farmers, very productively [14].

In [8], the authors proposed an intelligent water system which will go about as a benefit by optimizing the water system while showing the issue of water deficiency by initiating optimal utilization of water through modernized IoT based procedure. The brilliant irrigation module can be altered on particular need of different yields. This information can be put away on the server [9]. In view of the harvest chosen by the farmer on the mobile apps, information would be retrieved from the servers and the framework would modify itself accordingly, bringing about efficient irrigation system and expanded yields.

III. PROPOSED METHOD

Supervised Machine Learning algorithms, a previously labeled data for which the answers are already known is given to the machine to learn the patterns involved in it. It analyzes the different kinds of data, the answers for each different problem and gets a pattern involved in it. This phase is called training the data. The larger the data, the more accurate the results will be. The next stage involved in supervised machine learning is testing the data. In this phase, a problem is given to the machine to solve, the machine having known the pattern of solving the problem and the possible answers, gives the most suitable answer for it. As mentioned earlier the accuracy of the result will be based on the size of the data, the algorithms used in the data and various other factors like noise and outliers in the data given as input for training. Learning and prediction are the two major steps for any classification. The model is developed using the

feed training data in the learning step. The model should predict the results based on the training data in the prediction step. To perceive and interpret, decision tree algorithm, an efficient classification algorithm can be used.

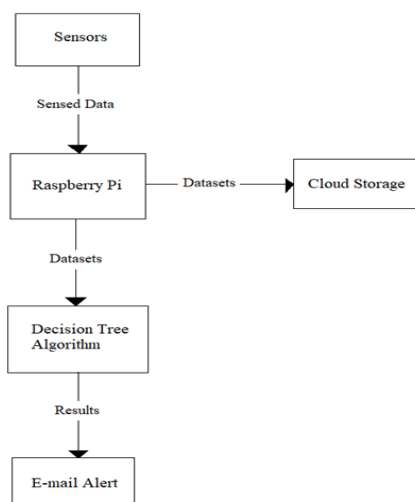

Figure 1. Data Flow Diagram

The data flow diagram represents the direction of flow of data regarding a system. It provides inputs and output of the entities present in the system. The data flow model for the proposed system is as in Figure 1.

A. Algorithm

- The decision tree algorithm is one of the efficient and simple algorithm among the supervised learning family of algorithms.
- The decision tree algorithm is used to solve several regression and classification problems, unlike from the other algorithms in supervised learning.
- The main objective of decision tree algorithm is to train the model which can predict the value or class of target variable by generating clear and uncomplicated decision rules derived from the previous data i.e., training data.
- To predict a class label of a record, it is required to start from the first node that is root node of the decision tree. The record's attribute should be validated with the values of each and every root attribute.
- Based on the validations, a path containing branches are followed with the matching value and jump to the succeeding node as shown in figure 2.

Terminology in decision trees are:

- Root node: It is a starting node or a parent node which is divided into two or more analogous sets.
- Leaf node: These are lower level nodes of the tree which doesn't split further.
- Decision node: It is a sub-node splitting into more sub-nodes.
- Splitting: It is a process of splitting a node into more nodes.
- Pruning: removing of sub-nodes, reverse process of splitting

- Sub-tree/Branch: It is a part of an entire decision tree.
- Child node: The node evolved from parent node by splitting

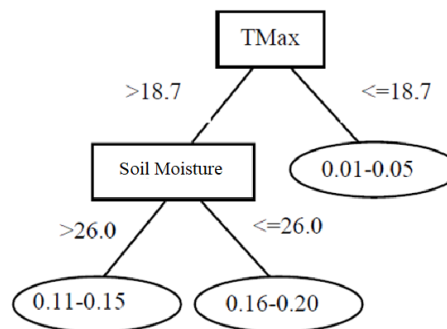

Figure 2. Sample Decision Tree

B. Architecture

The main components of the proposed system architecture are temperature, soil moisture, humidity sensors and raspberry pi.

- Raspberry Pi plays a central role in the system by providing storage to the datasets and hosting a web server.
- The DHT11 an Soil moisture sensor are deployed in the field and are connected to raspberry pi as shown in Figure 3.
- The data sensed through these sensors are sent to raspberry pi and are stored and processed in it.
- Decision tree algorithm is applied on the datasets in order to predict the accurate results.
- The result is sent to the farmer through an email regarding the water supply.
- All data sent from the sensors to the raspberry pi are stored in a cloud database for future use.

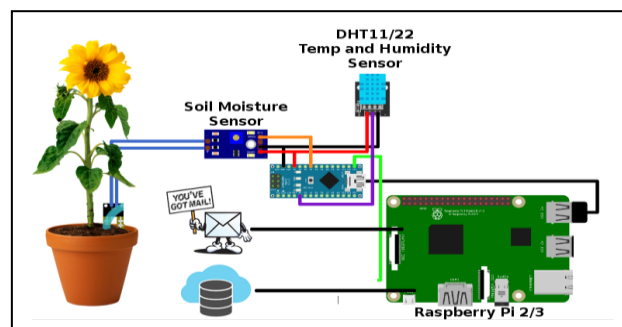

Figure 3. Architecture Diagram

C. Dataset

Datasets containing values of temperature, humidity and soil moisture are loaded into the decision tree algorithm. These datasets contain values of different scenarios in the fields in order to train the model accurately. The temperature is in Celsius, humidity and soil moisture are

represented in percentages. Sample datasets are as show in Table 1.

Table1. Sample Dataset

S.No.	Temperature (°C)	Humidity (%)	Soil Moisture (%)
1	36	76	81
2	40	85	70
3	39	73	72
4	41	79	71
5	44	73	65
6	43	75	76
7	36	73	69
8	38	62	48
9	47	67	74
10	51	69	58
11	53	67	45
12	48	93	57
13	49	90	35
14	29	76	67
15	31	74	64

IV. RESULTS

The sample output as shown in figure 4 contains the values of temperature in both Centigrade and Fahrenheit, humidity, water presence, and prints as well as sends an e-mail alert to farmer.

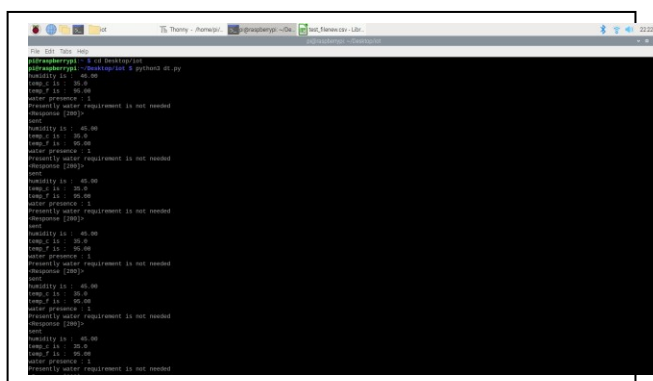

Figure 4. Sample Output

After applying decision tree algorithm on the sensed datasets, an output containing the decision to water the crop is made. This output containing decision is sent to the users or famers through an Electronic mail (E-mail) using Simple mail transfer protocol.

The two type of decisions are named as Yes and No.

- If the algorithm predicts the result as yes, then an alert is sent to farmer as shown in Figure 5.
- If the algorithm predicts the result as no, then alert is sent to farmer as shown in Figure 6.

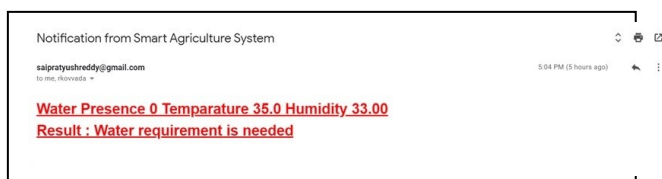

Figure 5. E-mail alert for Water requirement

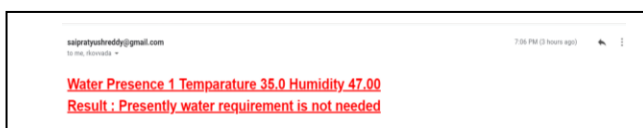

Figure 6. E-mail alert for No Water requirement

The values of temperature, humidity and water presence are also stored in a cloud storage for future references.

V. CONCLUSION

The work presented in this paper was highly motivated by the realization of future water scarcity that is going to create a great havoc. Agriculture is the significant occupation in India and these fields consumes large amount of water.

Greater than 80% of water resources are only used for the agriculture. This continuous trend may affect the water resources to be completely diminished. Taking this into consideration, a model was proposed to limit the water usage. For better land productivity, implementing smart technology in agricultural practices are need to be focused.

The system was programmed to be trained from the given dataset using all the sensed data from the soil moisture, temperature and humidity sensors. By applying the decision tree learning algorithm, which is from the family of supervised machine learning algorithms, on the real time data its processes and generates an output yes/no and sends the decision to the farmer through an email. Using this decision, a farmer can decide himself to water the crop only when required, avoiding the wastage of water use.

REFERENCES

- Dishay Kissoon, HinouchaDeerpaul and Avinash Mungur, "A Smart Irrigation and Monitoring System", *The International Journal of Computer Applications*, vol. 163, No. 8, Apr. 2017.
- P. Narayut, P. Sasimanee, C.-I. Anupong, P. Phond and A. Khajonpong, "A Control System in an Intelligent Farming by using Arduino Technology", Student Project Conference (ICT-ISP), 2016 Fifth ICT International, 27-28 May 2016.
- K. Benahmed, A. Douli, A. Bouzekri, M. Chabane and T. Benahmed, "Smart Irrigation Using Internet of Things", Fourth International Conference on Future Generation Communication Technology (FGCT), 29-31 Jul. 2015.
- A. N. Arvindan and D. Kartheeka, "Experimental investigation of remote control via Android smart phone of Arduino-based automated irrigation system using moisture sensor", 3rd International Conference on Electrical Energy Systems (ICEES), 17-19 Mar. 2016.
- T. Baranwal, N. and P. K. Pateriya, "Development of IoT based Smart Security and Monitoring Devices for Agriculture", 6th International Conference - Cloud System and Big Data Engineering (Confluence), 14-15 Jan. 2016.
- M. K. Gayatri, J. Jayasakthi and G.S.Anandha Mala, "Providing Smart Agriculture Solutions to Farmers for better yielding using IoT", IEEE Technological Innovation in ICT for Agriculture and Rural Development (TIAR), 10-12 Jul. 2015.
- Openweathermap.com, [2012-2016], Available from: <http://openweathermap.org/api>
- Kiran Shinde, Jerrin Andrei, AmeyOke, "Web Based Recommendation System for Farmers", *International Journal on Recent and Innovation Trends in Computing and Communication* 2, Volume: 3, Mar. 2014.
- Y. Mohana Roopa, et.al."A Survey of Fog Computing: Fundamental, Architecture, Applications and Challenges". IEEE International conference on IoT in Social, Mobile, analytics and Cloud ISMAC-19. December 12-14, 2019. ISBN: 978-1-7281-4364-4, Page No: 498-502.
- Mr. Ravi Kumar Banoth and Dr. A.P. Siva Kumar, "A Review on Machine Learning Algorithm Used for Crop Monitoring

- System in Agriculture”, *International Journal of Research*, Vol. 7, Issue 12, Dec. 2018.
- [11] Sanyam Gupta Sukriti, K. Indumathy, "IoT based smart irrigation and tank monitoring system", *International Journal of Innovative Research in Computer and Communication Engineering*, vol. 4, no. 9, September 2016.
- [12] Anuja Chandgude, Nikita Harpale, Diksha Jadhav, Punam Pawar and Suhas M. Patil, "A Review on Machine Learning Algorithm Used for Crop Monitoring System in Agriculture", *International Research journal of Engineering and Technology (IRJET)*, vol. 05, Issue 4, Apr. 2018.
- [13] Y. Mohana Roopa, et al., "Growing Trends in Indian Farming using Internet of Things (IoT)", *International Journal of Engineering and Advanced Technology*, ISSN: 2249-8958 (Online), Volume-9, Issue-2, December 2019, Pp- 4360-4364.
- [14] Decision Tree For Classification: A Machine Learning Algorithm, Available from: <https://www.xoriant.com/blog/product-engineering/decision-trees-machine-learning-algorithm.html>